

ARTOME M10







User guide

4.2

EN	User guide	1
FI	Käyttöohje	5
SV	Användarhandbok	9
NO	Brukerveiledning	13
DK	Brugervejledning	17
DE	Benutzerhandbuch	21
FR	Guide de l'utilisateur	25
ES	Guía del usuario	29
IT	Guida all'uso	33
NL	Gebruikershandleiding	37



Important safety information

 	<p>Unplug Artome from the outlet and refer all repairs to qualified service personnel in the following situations:</p> <ul style="list-style-type: none"> • Smoke, strange odors or strange noises come out of the Artome unit or the projector inside Artome. • Liquid or foreign objects get inside the Artome unit or the projector inside Artome. • Artome has been damaged. <p>If you continue using Artome as it is, it could cause an electric shock or fire. Do not try to repair the Artome unit yourself.</p> <p>Place Artome near an easily accessible outlet so that the plug can be unplugged immediately if an error occurs.</p>
	<p>Never open the Artome User Panel, Connection panel or Power panel. Never attempt to disassemble or modify the Artome unit (including installed projector).</p> <p>Electrical voltages inside the Artome unit can cause a fire, electrical shock, or severe injury.</p>
	<p>Never plug the Artome to the outlet before the projector is installed and the Artome unit is fully configured. This may harm the product.</p>
	<p>Installation and removal of the projector from the Artome unit must always be carried out by Artome authorised person. If the installation work is not carried out correctly, the product may not operate correctly and it may cause errors in the use of the product. Contact your dealer to carry out the installation work.</p>
	<p>Use only the power cord supplied by Artome. Using an improper power cord may cause fire or electric shock.</p>
	<p>Do not use a power cord that is damaged. Fire or electric shock may result.</p> <p>Follow these precautions when handling the power cord:</p> <ul style="list-style-type: none"> • Do not modify the power cord. • Do not place heavy objects on top of the power cord. • Do not bend, twist or pull the power cord excessively. • Keep the power cord away from hot electrical appliances. • Do not tie the power cord to other cables. <p>If the power cord is damaged, contact your dealer.</p>

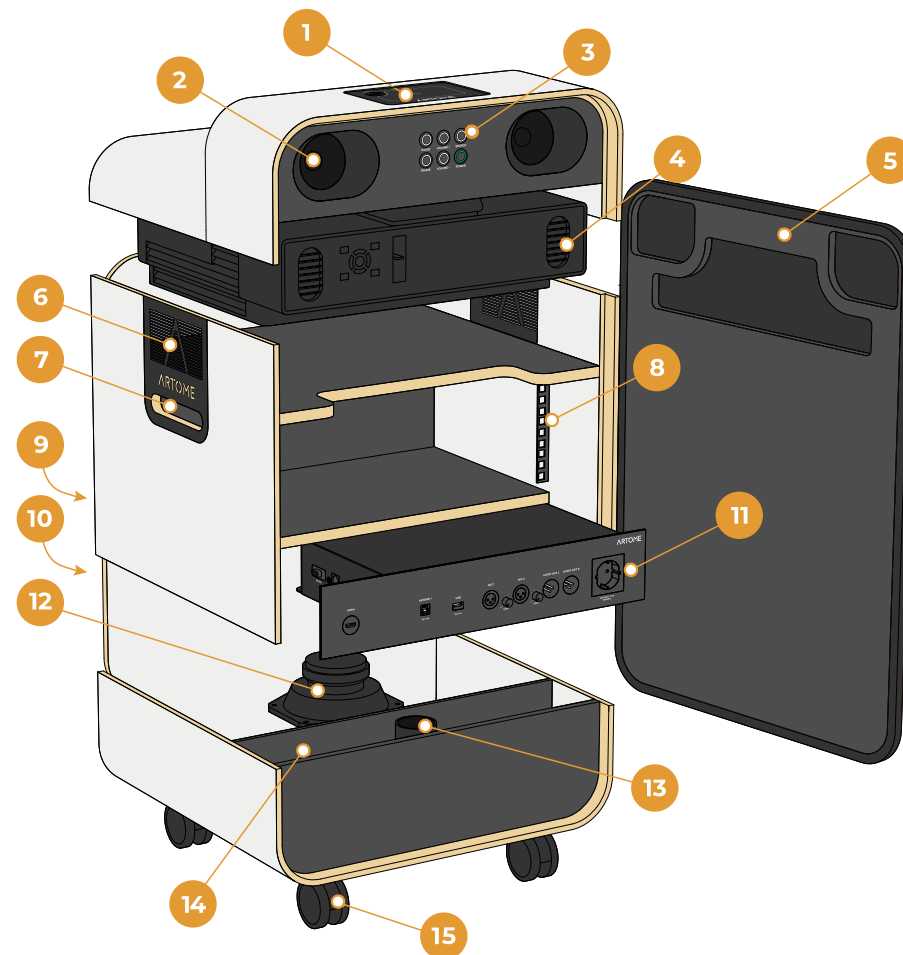

Description of the product

- | | |
|------------------|----------------------|
| 1. Top panel | 9. Back panel |
| 2. Speakers | 10. Main power |
| 3. Control panel | 11. Connection panel |
| 4. Projector | 12. Subwoofer |
| 5. Door | 13. Cable grommet |
| 6. Fan | 14. Cable space |
| 7. Lift handle | 15. Castors |
| 8. 19" rack | |

Artome support
support@artome.fi



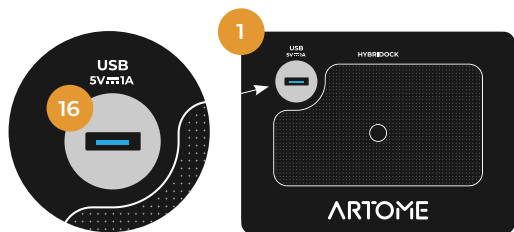

Top panel

16. USB for external camera

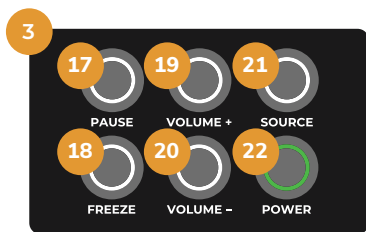

Control panel

17. PAUSE 20. VOLUME -
 18. FREEZE 21. SOURCE
 19. VOLUME + 22. POWER

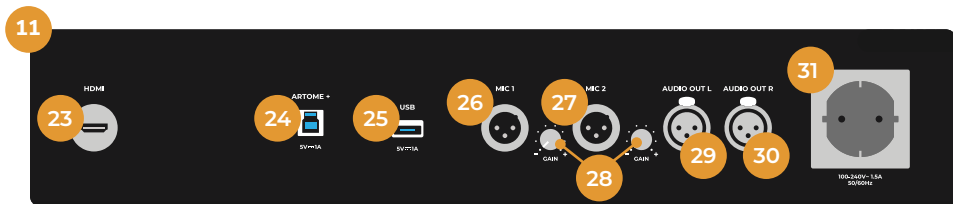

Connection panel

23. HDMI 27. MIC 2
 24. ARTOME+ 28. GAIN
 25. USB 29. AUDIO OUT L
 26. MIC 1 30. AUDIO OUT R
 31. Power socket

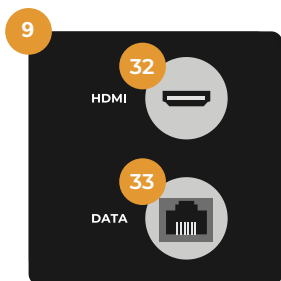

Back panel

32. HDMI
 33. DATA

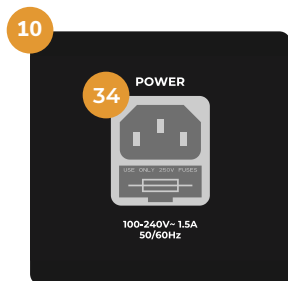

Main power

34. POWER



35. Power cable
 36. HDMI-USB Cable



37. Camera stand
 38. USB cable

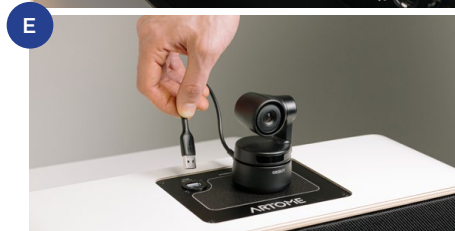

First time use

A. Connect the power cable (35) to the POWER connector on the back (34).

Open the front door (5) by pressing the door from the upper left corner.

B. Feed the HDMI-USB cable (36) through the cable grommet (13) and connect the cable to the Artome HDMI (23) and ARTOME+ (24) connectors.

C. Connect HDMI-USB cable (36) to your computer HDMI and USB A-ports. Use adapter if necessary.

Artome starts automatically when Artome detects HDMI from computer. If necessary, turn on the Artome from the Power button (22).

Using Artome in video conferencing

USB connects Artome and computer to external USB devices, which are needed for videoconferencing.

D. When using speakerphone for audio; install wireless USB Dongle of external speakerphone to USB port (25).







E. Connect the USB cable (38) to the camera. Place the camera on the top panel (1) and connect the cable to the USB port (16). If necessary, use the magnetic camera stand (37).

Using Artome for speeches

F. Connect a dynamic microphone to MIC (26-27) connection with XLR cable. Mic input volume can be adjusted with GAIN controls (28).

If more sound is needed, connect additional active speakers to Audio Out connection (29-30) with XLR cable.

Tärkeitä turvallisuustietoja

 	<p>Irrota Artome pistorasiasta ja anna kaikki korjaukset pätevän huoltohenkilöstön tehtäväksi seuraavissa tilanteissa:</p> <ul style="list-style-type: none"> • Artome-yksiköstä tai Artomen sisällä olevasta projektorista tulee savua, outoja hajuja tai outoja ääniä. • Nestettä tai vieraita esineitä pääsee Artome-yksikön tai Artomen sisällä olevan projektorin sisään. • Artome on vahingoittunut. <p>Jos jatkat Artomen käyttöä sellaisenaan, se voi aiheuttaa sähköiskun tai tulipalon. Älä yritä korjata Artome-yksikköä itse.</p> <p>Sijoita Artome helposti saatavilla olevan pistorasian lähelle, jotta pistoke voidaan irrottaa välittömästi, jos vika ilmenee.</p>
	<p>Älä koskaan avaa Artomen käyttäjäpaneelia, liitäntäpaneelia tai virtapaneelia. Älä koskaan yritä purkaa tai muuttaa Artome-yksikköä (mukaan lukien asennettu projektori).</p> <p>Artome-yksikön sisällä olevat sähköjännitteet voivat aiheuttaa tulipalon, sähköiskun tai vakavan loukkaantumisen.</p>
	<p>Älä koskaan kytke Artome-yksikköä pistorasiaan ennen kuin projektori on asennettu ja Artome-yksikkö on täysin kytketty. Tämä voi vahingoittaa tuotetta.</p>
	<p>Projektin asennus ja irrottaminen Artome-yksiköstä on aina suoritettava Artomen valtuuttaman henkilön toimesta. Jos asennustyötä ei suoriteta oikein, tuote ei välttämättä toimi oikein ja se voi aiheuttaa virheitä tuotteen käytössä. Ota yhteys jälleenmyyjään asennustyön suorittamiseksi.</p>
	<p>Käytä vain Artomen toimittamaa virtajohtoa. Vääränlaisen virtajohdon käyttö voi aiheuttaa tulipalon tai sähköiskun.</p>
	<p>Älä käytä vaurioitunutta virtajohtoa. Tulipalo tai sähköisku voi olla seurauksena.</p> <p>Noudata näitä varoitusmerkkejä käsitellessäsi virtajohtoa:</p> <ul style="list-style-type: none"> • Älä muokkaa virtajohtoa. • Älä aseta painavia esineitä virtajohdon päälle. • Älä taivuta, väännä tai vedä virtajohtoa liikaa. • Pidä virtajohto kaukana kuumista sähkölaitteista. • Älä sido virtajohtoa muihin kaapeleihin. <p>Jos virtajohto on vaurioitunut, ota yhteys jälleenmyyjään.</p>

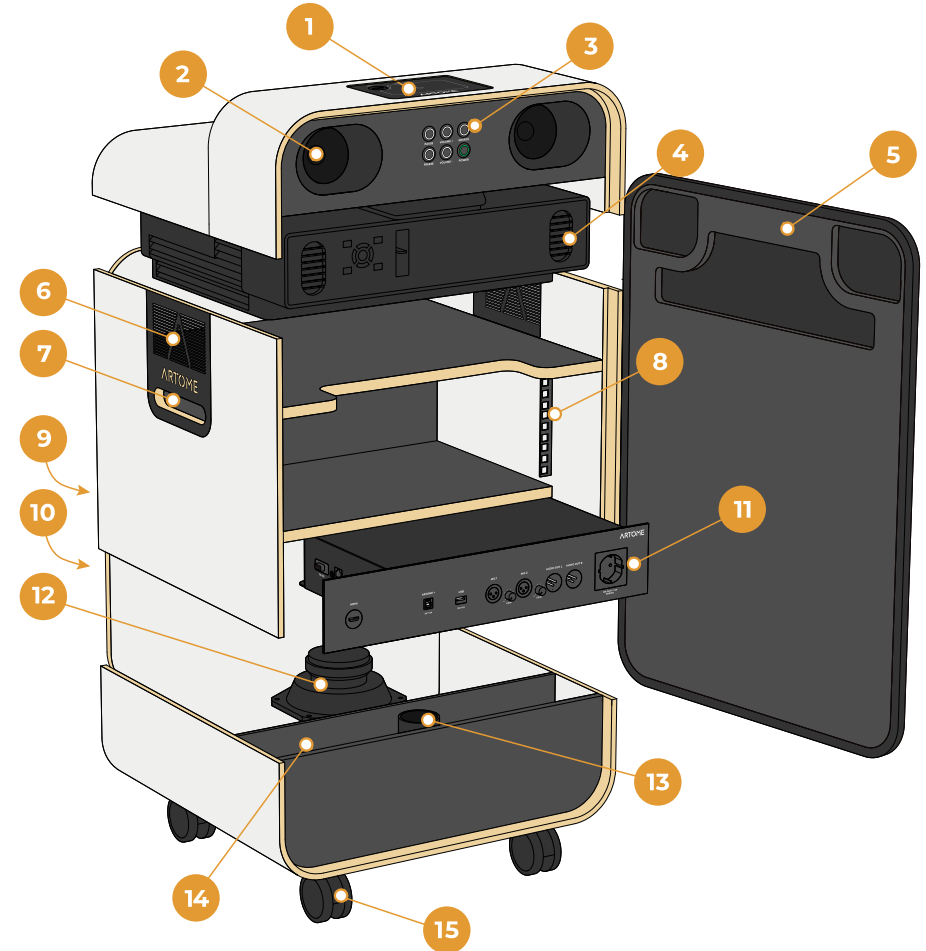

Tuotteen kuvaus

- | | |
|-------------------|-----------------------|
| 1. Kansipaneeli | 9. Takapaneeli |
| 2. Kaiuttimet | 10. Päävirta |
| 3. Käyttöpaneeli | 11. Liitinpaneeli |
| 4. Projektori | 12. Subwoofer |
| 5. Ovi | 13. Kaapeliläpivienti |
| 6. Tuuletin | 14. Kaapelitila |
| 7. Nostokahva | 15. Renkaat |
| 8. 19" laiteräkki | |

Artome support
support@artome.fi





Kansipaneeli

16. USB ulkoista kameraa varten

Käyttöpaneeli

17. PAUSE 20. VOLUME -
18. FREEZE 21. SOURCE
19. VOLUME + 22. POWER

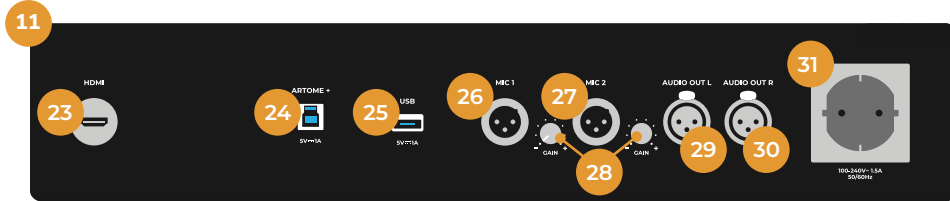

Liitinpaneeli

23. HDMI 27. MIC 2
24. ARTOME+ 28. GAIN
25. USB 29. AUDIO OUT L
26. MIC 1 30. AUDIO OUT R
31. Virtapistoke

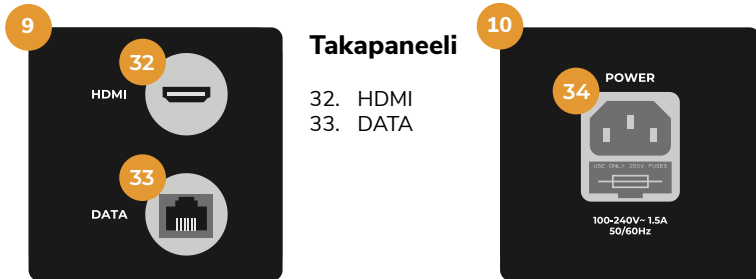

Takapaneeli

32. HDMI
33. DATA

Päävirta

34. POWER



35. Virtajohto
36. HDMI-USB-kaapeli

37. Kameran jalusta
38. USB-kaapeli



Ensimmäinen käyttökerta

A. Kytke virtajohto (35) POWER-liittimeen (34).

Avaa etuovi (5) painamalla vasemmasta yläkulmasta.

B. Vie HDMI-USB-kaapeli (36) kaapeliläpiviennin (13) läpi ja liitä kaapeli Artome HDMI (23) ja ARTOME+ (24) -liittimiin.

C. Liitä HDMI-USB-kaapeli (36) tietokoneen HDMI- ja USB A-portteihin. Käytä tarvittaessa sovitinta.

Artome käynnistyy automaattisesti, kun Artome havaitsee HDMI:n tietokoneesta. Kytke Artome tarvittaessa päälle POWER-painikkeesta (22).

Artomen käyttäminen videoneuvotteluissa

USB yhdistää Artomen ja tietokoneen ulkoisiin USB-laitteisiin, joita tarvitaan videoneuvotteluissa.

D. Kun käytät kaiutinpuhelinta äänentoistoon; asenna ulkoisen kaiutinpuhelimen langaton USB-dongle USB-porttiin (25).







E. Liitä USB-kaapeli (38) kameraan. Aseta kamera kansipaneelin (1) päälle ja liitä kaapeli USB-liitäntään (16). Käytä tarvittaessa magneettista kameran jalustaa (37).

Artomen käyttäminen puhetilaisuuksissa

F. Kytke dynaaminen mikrofoni MIC (26-27) -liitäntään XLR-kaapelilla. Mikrofonitulon äänenvoimakkuutta voidaan säätää GAIN-säätimillä (28).

Jos tarvitset enemmän ääntä, liitä ulkoiset aktiivikaiuttimet Audio Out -liitäntään (29-30) XLR-kaapelilla.

Viktig säkerhetsinformation

 	<p>Dra ut Artome ur eluttaget och hänvisa alla reparationer till kvalificerad servicepersonal i följande situationer:</p> <ul style="list-style-type: none"> Rök, konstiga lukter eller konstiga ljud kommer ut från Artome-enheten eller projektorn inuti Artome. Vätska eller främmande föremål kommer in i Artome-enheten eller projektorn inuti Artome. Artome -produkten har skadats. <p>Om du fortsätter att använda Artome i oförändrat skick kan det orsaka en elektrisk stöt eller brand. Försök inte att reparera Artome-enheten själv.</p> <p>Placera Artomen nära ett lättåtkomligt uttag så att kontakten kan dras ur omedelbart om ett fel uppstår.</p>
	<p>Öppna aldrig Artomes användarpanel, anslutningspanel eller strömpanel. Försök aldrig demontera eller ändra Artome-enheten (inklusive installerad projektor).</p> <p>Elektrisk spänning inuti Artome-enheten kan orsaka brand, elektrisk stöt eller allvarig skada.</p>
	<p>Anslut aldrig Artome till eluttaget innan projektorn är installerad och Artome-enheten är färdigkonfigurerad. Detta kan skada produkten.</p>
	<p>Installation och borttagning av projektorn från Artome-enheten måste alltid utföras av en Artome-auktoriserad person. Om installationsarbetet inte utförs korrekt kan det orsaka att produkten inte fungerar korrekt. Det kan även orsaka fel i användningen av produkten. Kontakta din återförsäljare för att utföra installationsarbetet.</p>
	<p>Använd endast den strömkabel som förses av Artome. Användning av en felaktig strömkabel kan orsaka brand eller elektrisk stöt.</p>
	<p>Använd inte en strömkabel som är skadad. Brand eller elektrisk stöt kan uppstå.</p> <p>Följ dessa försiktighetsåtgärder när du hanterar strömkabeln:</p> <ul style="list-style-type: none"> Gör inga ändringar åt strömkabeln. Placera inte tunga föremål ovanpå strömkabeln. Böj, vrid eller dra inte överdrivet mycket i strömkabeln. Håll strömkabeln borta från heta elektriska apparater. Knyt inte strömkabeln till andra kablar. <p>Om strömkabeln är skadad, kontakta din återförsäljare.</p>

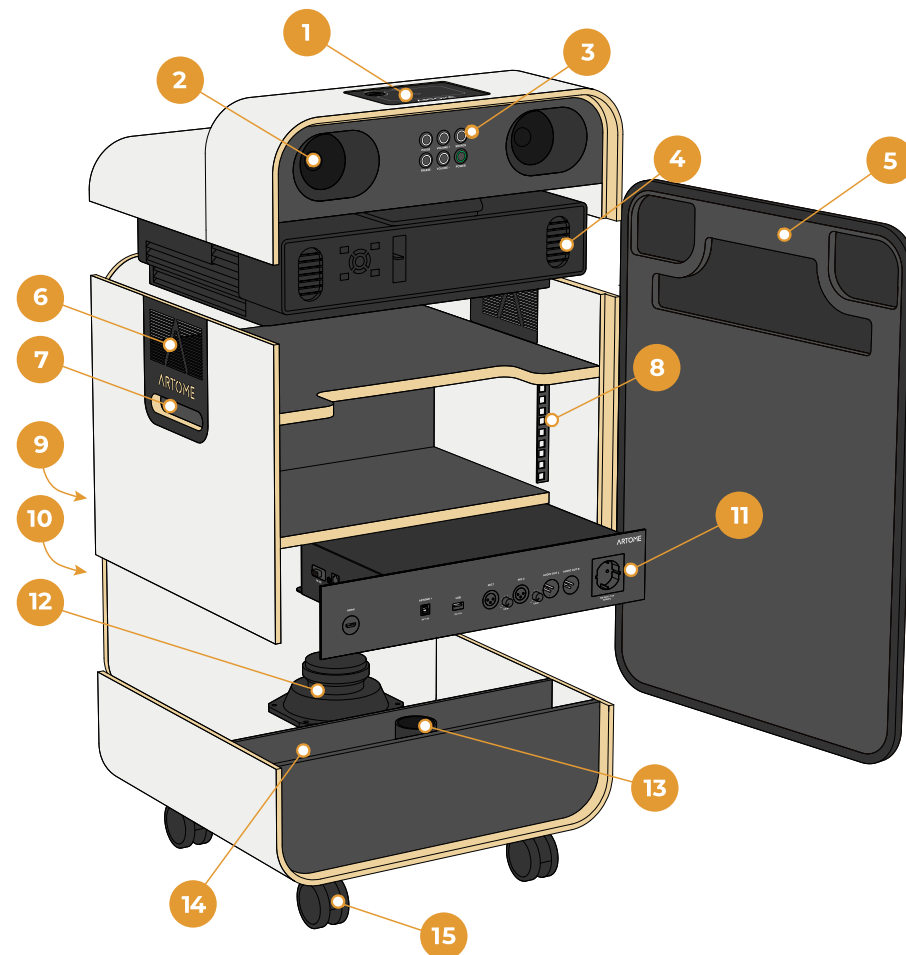

Beskrivning av produkten

- | | |
|------------------|----------------------|
| 1. Översta panel | 9. Bakre panel |
| 2. Högtalare | 10. Huvudström |
| 3. Användarpanel | 11. Anslutningspanel |
| 4. Projektor | 12. Subwoofer |
| 5. Dörr | 13. Kabelgenomföring |
| 6. Fläkt | 14. Kabelutrymme |
| 7. Lyfthandtag | 15. Hjul |
| 8. 19" rack | |

Artome support
support@artome.fi



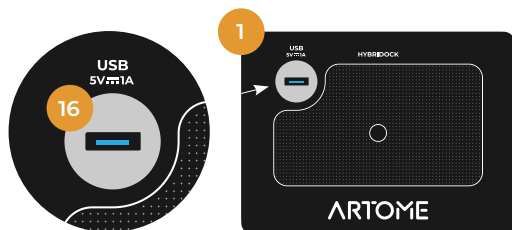

Översta panel

16. USB för extern kamera

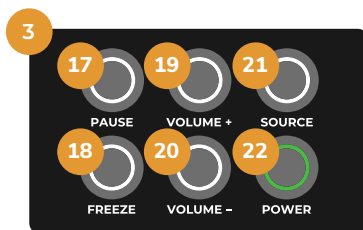

Användarpanel

17. PAUSE 20. VOLUME -
18. FREEZE 21. SOURCE
19. VOLUME + 22. POWER

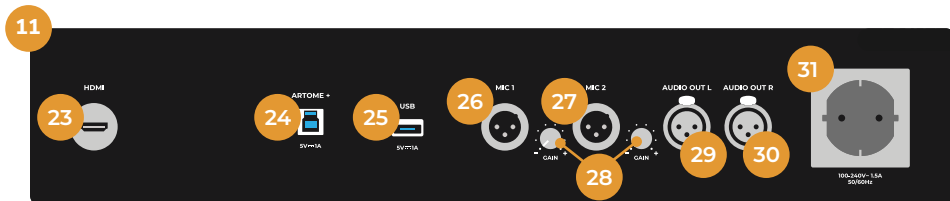

Anslutningspanel

23. HDMI 27. MIC 2
24. ARTOME+ 28. GAIN
25. USB 29. AUDIO OUT L
26. MIC 1 30. AUDIO OUT R
31. Eluttag

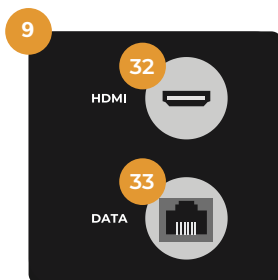

Bakre panel

32. HDMI
33. DATA

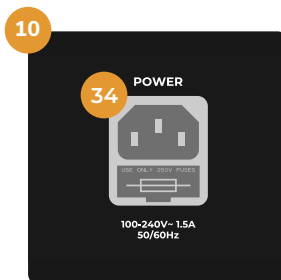

Huvudström

34. POWER



35. Strömkabel
36. HDMI-USB -kabel



37. Stativ för kameran
38. USB -kabel

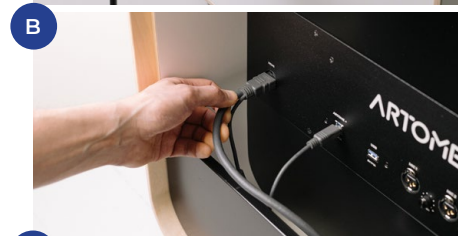

Första användningen

A. Anslut strömkabeln (35) till strömkontakten (34).

Öppna den främre dörren (5) genom att trycka på dörren i det övre vänstra hörnet.

B. För HDMI-USB-kabeln (36) genom kabelgenomföringen (13) och anslut kabeln till anslutningarna Artome HDMI (23) och ARTOME+ (24).

C. Anslut HDMI-USB-kabeln (36) till datorns HDMI- och USB A-portar. Använd en adapter om det behövs.

Artome startar automatiskt när Artome upptäcker inkommande signal via HDMI från datorn. Vid behov kan du slå på Artomen med hjälp av strömknappen (22).

Användning av Artome i videokonferenser

USB ansluter Artomen och datorn till externa USB-enheter, som behövs för videokonferenser.

D. När du använder konferenstelefon för ljud, installera trådlös USB-dongel för extern högtalartelefon i USB-porten (25).







E. Anslut USB-kabeln (38) till kameran. Placera kameran på översta panelen (1) och anslut kabeln till USB-porten (16). Använd vid behov det magnetiska kamerastativet (37).

Användning av Artome för tal

F. Anslut en dynamisk mikrofon till MIC (26-27) med XLR-kabel. Mikrofonens ingångsvolym kan justeras med GAIN-kontrollerna (28).

Om du behöver mer ljud kan du ansluta ytterligare aktiva högtalare till Audio Out-anslutningen (29-30) med XLR-kabel.

Viktig sikkerhetsinformasjon

 	<p>Trekk ut støpselet til Artome fra stikkkontakten og overlat alle reparasjoner til kvalifisert servicepersonell i følgende situasjoner:</p> <ul style="list-style-type: none"> Røyk, merkelig lukt eller merkelige lyder kommer fra Artome-enheten eller projektoren inne i Artome. Væske eller fremmedlegemer kommer inn i Artome-enheten eller projektoren inne i Artome. Artome-produktet har blitt skadet. <p>Hvis du fortsetter å bruke Artome uendret, kan det føre til elektrisk støt eller brann. Ikke forsøk å reparere Artome-enheten selv.</p> <p>Plasser Artome i nærheten av et lett tilgjengelig strømuttak slik at støpselet kan trekkes ut umiddelbart hvis det oppstår en funksjonsfeil.</p>
	<p>Åpne aldri Artomes brukerpanel, tilkoblingspanel eller strømpanel. Forsøk aldri å demontere eller modifisere Artome-enheten (inkludert den installerte projektoren).</p> <p>Elektrisk spenning inne i Artome-enheten kan forårsake brann, elektrisk støt eller alvorlig personskade.</p>
	<p>Koble aldri Artome til strømuttaket før projektoren er installert og Artome-enheten er fullstendig konfigurert. Dette kan skade produktet.</p>
	<p>Installasjon og fjerning av projektoren fra Artome-enheten må alltid utføres av en Artome- autorisert person. Unnlattelse av å utføre installasjonsarbeidet på riktig måte kan føre til at produktet ikke fungerer som det skal. Det kan også føre til feil i bruken av produktet. Kontakt forhandleren din for å utføre installasjonsarbeidet.</p>
	<p>Bruk kun strømkabelen som leveres av Artome. Bruk av feil strømkabel kan føre til brann eller elektrisk støt.</p>
	<p>Ikke bruk en strømledning som er skadet. Det kan føre til brann eller elektrisk støt.</p> <p>Følg disse forholdsreglene når du håndterer strømkabelen:</p> <ul style="list-style-type: none"> Ikke gjør noen endringer på strømkabelen. Ikke plasser tunge gjenstander oppå strømkabelen. Ikke bøy, vri eller trekk for mye i strømkabelen. Hold strømkabelen borte fra varme elektriske apparater. Ikke fest strømkabelen til andre kabler. <p>Kontakt forhandleren hvis strømkabelen er skadet.</p>

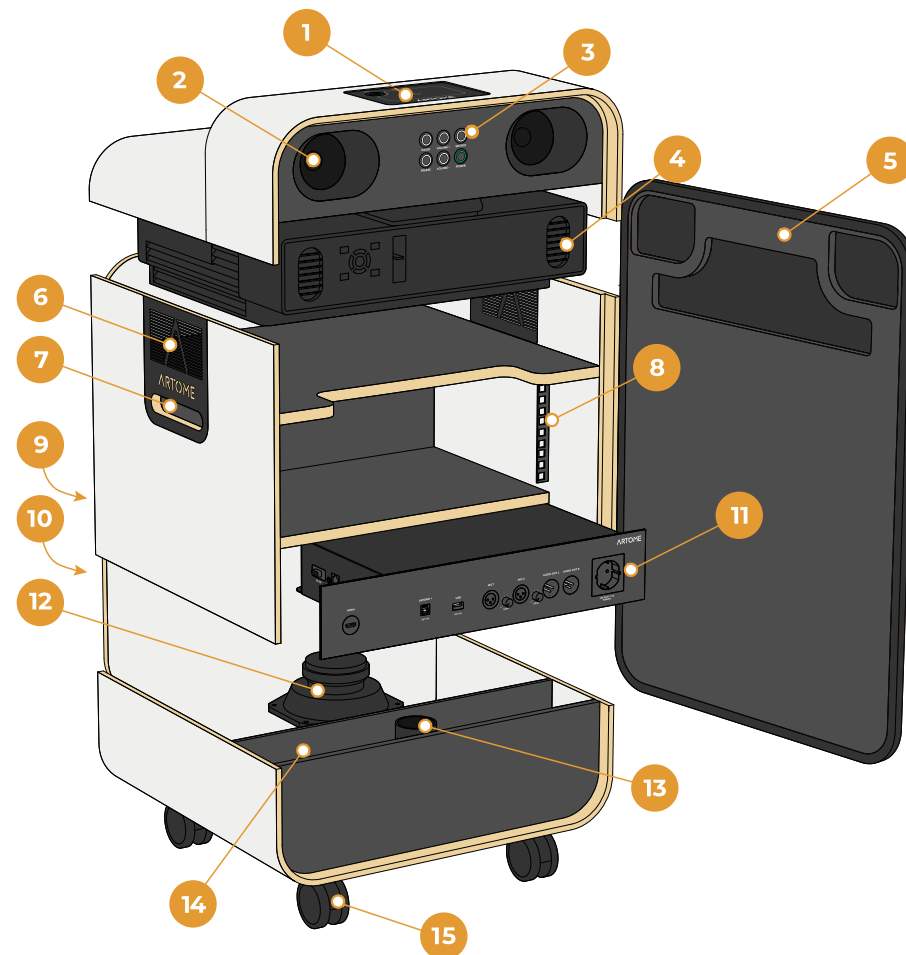

Beskrivelse av produktet

- | | |
|-----------------|----------------------|
| 1. Toppanel | 9. Bakre panel |
| 2. Høyttalere | 10. Hovedstrøm |
| 3. Brukerpanel | 11. Tilkoblingspanel |
| 4. Projektor | 12. Subwoofer |
| 5. Dør | 13. Kabelinngang |
| 6. Vifte | 14. Kabelrom |
| 7. Løftehåndtak | 15. Hjul |
| 8. 19" rack | |

Artome support
support@artome.fi



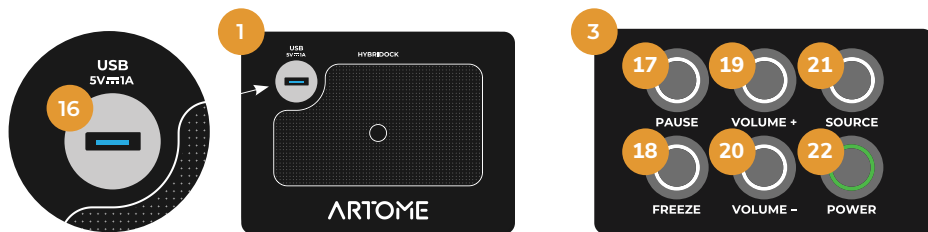

Toppanel

16. USB för externt kamera

Brukerpanel

17. PAUSE 20. VOLUME -
18. FREEZE 21. SOURCE
19. VOLUME + 22. POWER

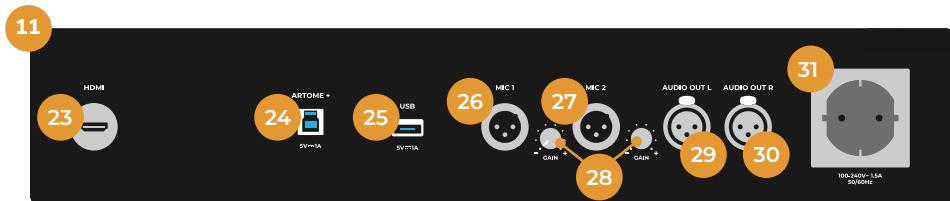

Tilkoblingspanel

23. HDMI 27. MIC 2
24. ARTOME+ 28. GAIN
25. USB 29. AUDIO OUT L
26. MIC 1 30. AUDIO OUT R
31. Strømuttak

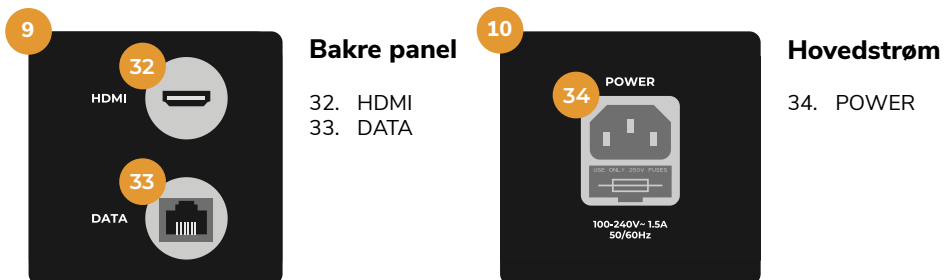

Bakre panel

32. HDMI
33. DATA

Hovedstrøm

34. POWER

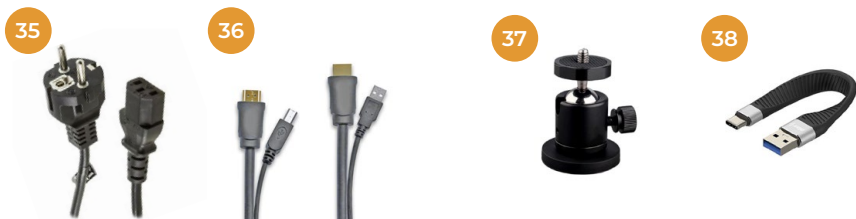

35. Strømkabel
36. HDMI-USB-kabel

37. Stativ for kamera
38. USB-kabel

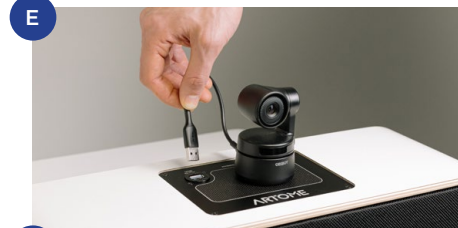
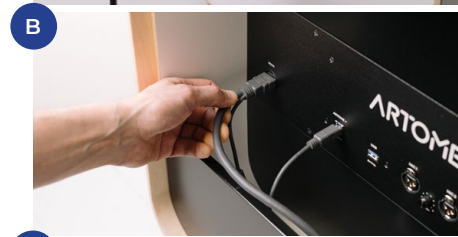

Første bruk

A. Koble strømkabelen (35) til strømkontakten (34).

Åpne frontdøren (5) ved å trykke på døren i øvre venstre hjørne.

B. Før HDMI-USB-kabelen (36) gjennom kabelinngangen (13) og koble kabelen til kontaktene Artome HDMI (23) og ARTOME+ (24).

C. Koble HDMI-USB-kabelen (36) til datamaskinens HDMI- og USB A-porter. Bruk en adapter om nødvendig.

Artome starter automatisk når Artome registrerer innkommende signal via HDMI fra datamaskinen. Om nødvendig kan du slå på Artome med strømknappen (22).

Bruke Artome i videokonferanser

USB kobler Artome og datamaskinen til eksterne USB-enheter som er nødvendige for videokonferanser.

D. Når du bruker konferansetelefonen for lyd, installerer du den trådløse USB-dongelen for ekstern høyttalertelefon i USB-porten (25).







E. Koble USB-kabelen (38) til kameraet. Plasser kameraet på topppanelet (1) og koble kabelen til USB-porten (16). Bruk om nødvendig det magnetiske kamerastativet (37).

Bruke Artome til tale

F. Koble en dynamisk mikrofon til MIC-tilkoblingen (26-27) med XLR-kabel. Volumet på mikrofoninngangen kan justeres med GAIN-kontrollene (28).

Hvis du trenger mer lyd, kan du koble flere aktive høyttalere til Audio Out-tilkoblingen (29-30) med XLR-kabel.

Vigtige sikkerhedsoplysninger

 	<p>Tag Artome ud af stikkontakten, og henvis alle reparationer til kvalificeret servicepersonale i følgende situationer:</p> <ul style="list-style-type: none"> • Der kommer røg, mærkelige lugte eller mærkelige lyde fra Artome-enheden eller projektoren inde i Artome. • Der trænger væske eller fremmedlegemer ind i Artome-enheden eller projektoren inde i Artome. • Artome-produktet er blevet beskadiget. <p>Hvis du fortsætter med at bruge Artome uændret, kan det forårsage elektrisk stød eller brand. Forsøg ikke selv at reparere Artome-enheden.</p> <p>Placer Artome i nærheden af en let tilgængelig stikkontakt, så stikket kan trækkes ud med det samme, hvis der opstår en fejlfunktion.</p>
	<p>Åbn aldrig Artomes brugerpanel, tilslutningspanel eller strømpanel. Forsøg aldrig at adskille eller ændre Artome-enheden (herunder den installerede projektor).</p> <p>Elektrisk spænding inde i Artome-enheden kan forårsage brand, elektrisk stød eller alvorlig personskade.</p>
	<p>Tilslut aldrig Artome til stikkontakten, før projektoren er installeret, og Artome-enheden er fuldt konfigureret. Dette kan beskadige produktet.</p>
	<p>Installation og afmontering af projektoren fra Artome-enheden skal altid udføres af Artome-autoriserede personer. Hvis installationsarbejdet ikke udføres korrekt, kan produktet komme til at fungere dårligt. Det kan også medføre fejl i brugen af produktet. Kontakt din forhandler for at få udført installationsarbejdet.</p>
	<p>Brug kun det strømkabel, der leveres af Artome. Brug af et forkert strømkabel kan forårsage brand eller elektrisk stød.</p>
	<p>Brug ikke et netkabel, der er beskadiget. Der kan opstå brand eller elektrisk stød.</p> <p>Følg disse forholdsregler, når du håndterer strømkablet:</p> <ul style="list-style-type: none"> • Foretag ingen ændringer på strømkablet. • Placer ikke tunge genstande oven på strømkablet. • Bøj, drej eller træk ikke overdrevent meget i strømkablet. • Hold netkablet væk fra varme elektriske apparater. • Bind ikke strømkablet til andre kabler. <p>Hvis strømkablet er beskadiget, skal du kontakte din forhandler.</p>

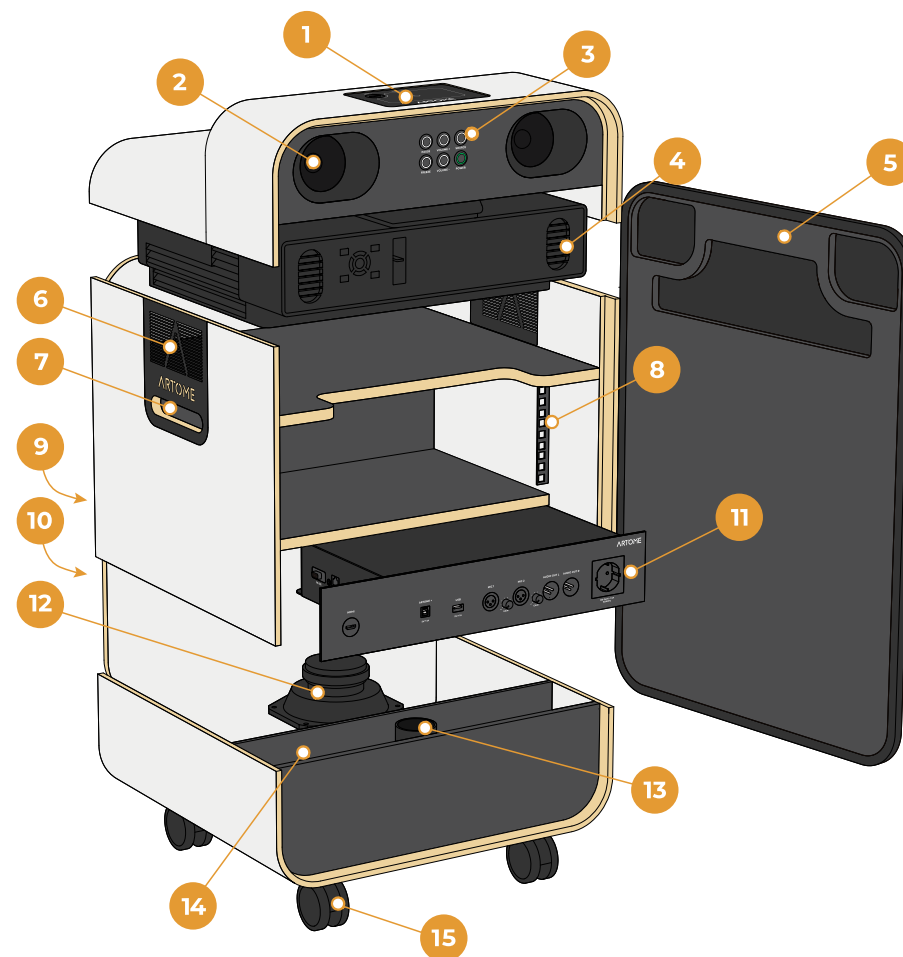

Beskrivelse af produktet

- | | |
|------------------|-----------------------|
| 1. Øverste panel | 9. Bagpanel |
| 2. Højtalere | 10. Hovedstrøm |
| 3. Brugerpanel | 11. Tilslutningspanel |
| 4. Projektor | 12. Subwoofer |
| 5. Dør | 13. Kabelindføring |
| 6. Ventilator | 14. Kabelrum |
| 7. Løftehåndtag | 15. Hjul |
| 8. 19" rack | |

Artome support
support@artome.fi



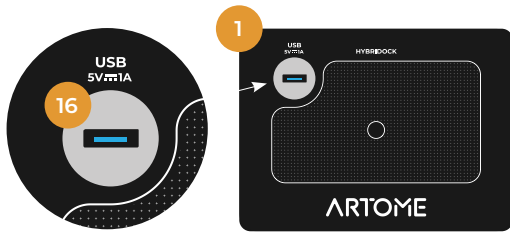

Øverste panel

16. USB til eksternt kamera

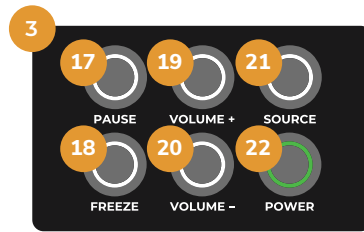

Brugerpanel

17. PAUSE 20. VOLUME -
18. FREEZE 21. SOURCE
19. VOLUME + 22. POWER

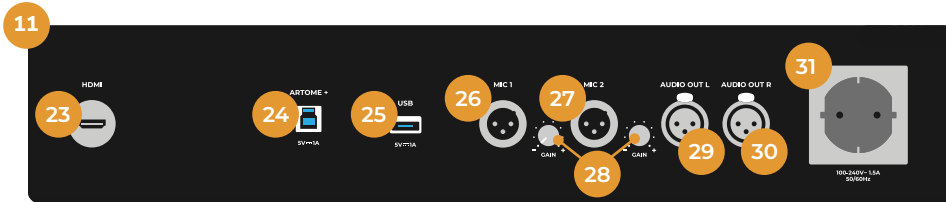

Tilslutningspanel

23. HDMI 27. MIC 2
24. ARTOME+ 28. GAIN
25. USB 29. AUDIO OUT L
26. MIC 1 30. AUDIO OUT R
31. Strømskik

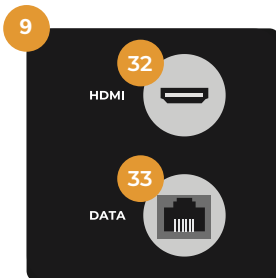

Bagpanel

32. HDMI
33. DATA

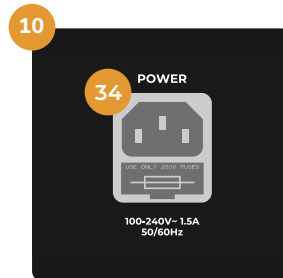

Hovedstrøm

34. POWER



35. Strømkabel
36. HDMI-USB-kabel



37. Stativ til kamera
38. USB-kabel

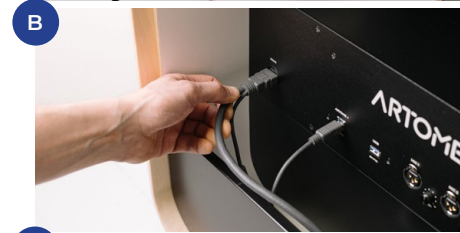

Første brug

A. Tilslut strømkablet (35) til strømkontakten (34).

Åbn frontdøren (5) ved at trykke på døren i det øverste venstre hjørne.

B. Før HDMI-USB-kablet (36) gennem kabelindføringen (13) og tilslut kablet til Artome HDMI (23) og ARTOME+ (24) stikkene.

C. Tilslut HDMI-USB-kablet (36) til computerens HDMI- og USB A-porte. Brug om nødvendigt en adapter.

Artome starter automatisk, når Artome registrerer indgående signal via HDMI fra computeren. Hvis det er nødvendigt, kan du tænde Artome ved hjælp af tænd/sluk-knappen (22).

Brug af Artome i videokonferencer

USB forbinder Artome og computeren med eksterne USB-enheder, som er nødvendige til videokonferencer.

D. Tilslut USB-kablet (38) til kameraet. Placer kameraet på øverste panelet (1), og tilslut kablet til USB-porten (16). Brug om nødvendigt det magnetiske kamerastativ (37).







E. Placer kameraet på øverste panelet (1), og tilslut USB-kablet (38) til USB-stikket (24).

Brug af Artome til tale

F. Tilslut en dynamisk mikrofon til MIC-tilslutningen (26-27) med et XLR-kabel. Mikrofonindgangens lydstyrke kan justeres med GAIN-kontrollerne (28).

Hvis du har brug for mere lyd, kan du tilslutte ekstra aktive højttalere til Audio Out-tilslutningen (29-30) med et XLR-kabel.

Wichtige Sicherheitsinformationen

 	<p>Ziehen Sie den Stecker des Artome aus der Steckdose und überlassen Sie alle Reparaturen qualifiziertem Servicepersonal, wenn folgende Situationen eintreten:</p> <ul style="list-style-type: none"> • Aus dem Artome-Gerät oder dem Projektor im Artome treten Rauch, seltsame Gerüche oder seltsame Geräusche aus. • Flüssigkeit oder Fremdkörper gelangen in das Innere des Artome-Geräts oder des Projektors im Artome. • Der Artome ist beschädigt worden. <p>Wenn Sie Artome weiterhin so verwenden, besteht die Gefahr eines elektrischen Schlags oder Brands. Versuchen Sie nicht, das Artome-Gerät selbst zu reparieren.</p> <p>Stellen Sie Artome in der Nähe einer leicht zugänglichen Steckdose auf, damit der Stecker im Falle eines Fehlers sofort herausgezogen werden kann.</p>
	<p>Öffnen Sie niemals das Artome-Bedienfeld, das Anschlussfeld oder das Netzfeld. Versuchen Sie niemals, das Artome-Gerät (einschließlich des installierten Projektors) zu zerlegen oder zu verändern.</p> <p>Elektrische Spannungen im Inneren des Artome-Geräts können einen Brand, einen elektrischen Schlag oder schwere Verletzungen verursachen.</p>
	<p>Schließen Sie den Artome niemals an die Steckdose an, bevor der Projektor installiert und der Artome vollständig angeschlossen ist. Dies kann das Gerät beschädigen.</p>
	<p>Die Installation und der Ausbau des Projektors aus dem Artome-Gerät muss immer von einer von Artome autorisierten Person durchgeführt werden. Wenn die Installation nicht ordnungsgemäß durchgeführt wird, funktioniert das Gerät möglicherweise nicht richtig und es kann zu Fehlern bei der Verwendung des Geräts kommen. Wenden Sie sich an Ihren Händler, um die Installation vorzunehmen.</p>
	<p>Verwenden Sie nur das von Artome gelieferte Netzkabel. Die Verwendung eines ungeeigneten Netzkabels kann zu Bränden oder Stromschlägen führen.</p>
	<p>Verwenden Sie kein beschädigtes Netzkabel. Dies kann zu Bränden oder Stromschlägen führen.</p> <p>Beachten Sie die folgenden Vorsichtsmaßnahmen beim Umgang mit dem Netzkabel:</p> <ul style="list-style-type: none"> • Verändern Sie das Netzkabel nicht. • Stellen Sie keine schweren Gegenstände auf das Netzkabel. • Biegen, verdrehen oder ziehen Sie das Netzkabel nicht zu stark. • Halten Sie das Netzkabel von heißen Elektrogeräten fern. • Verbinden Sie das Netzkabel nicht mit anderen Kabeln. <p>Wenn das Netzkabel beschädigt ist, wenden Sie sich an Ihren Händler.</p>

Artome support
support@artome.fi

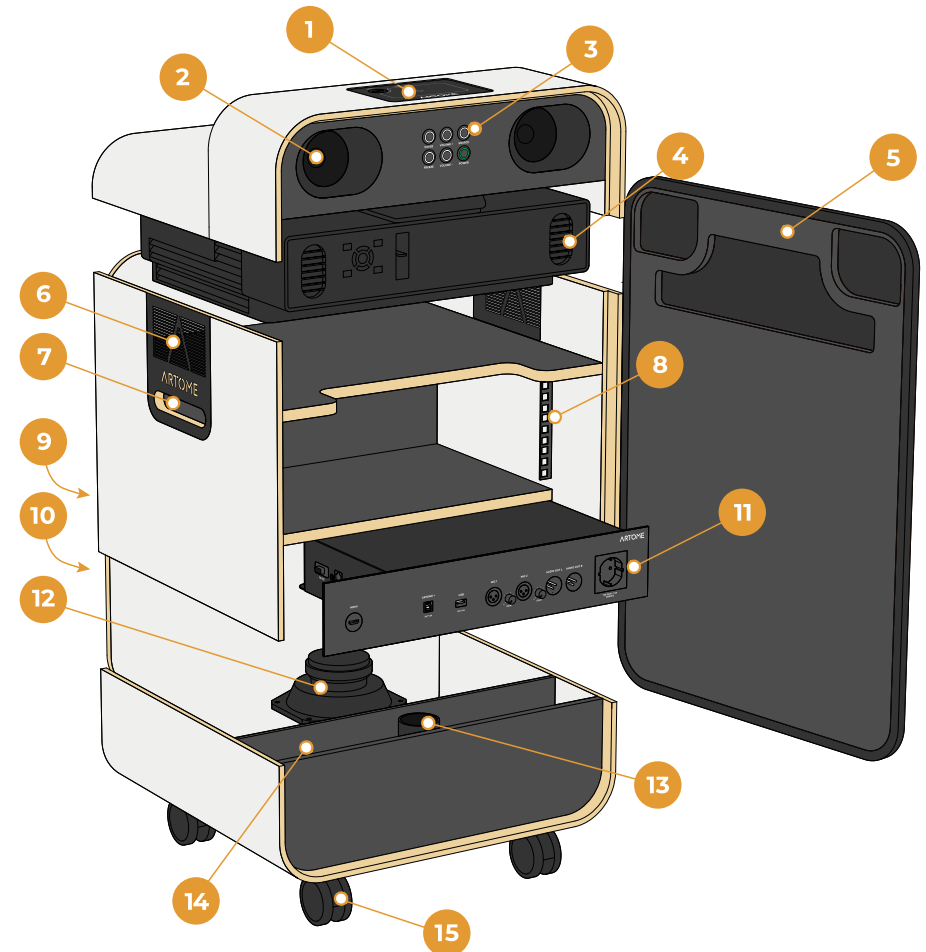

Beschreibung des Produkts

- | | |
|-----------------|-----------------------|
| 1. Obere panel | 9. Rück panel |
| 2. Lautsprecher | 10. Hauptstrom |
| 3. Bedienfeld | 11. Anschlusspanel |
| 4. Projektor | 12. Subwoofer |
| 5. Tür | 13. Kabeldurchführung |
| 6. Lüfter | 14. Platz für Kabel |
| 7. Hebegriff | 15. Laufrollen |
| 8. 19" rack | |



Obere panel

16. USB für externe Kamera

Benutzerpanel

17. PAUSE 20. VOLUME -
18. FREEZE 21. SOURCE
19. VOLUME + 22. POWER

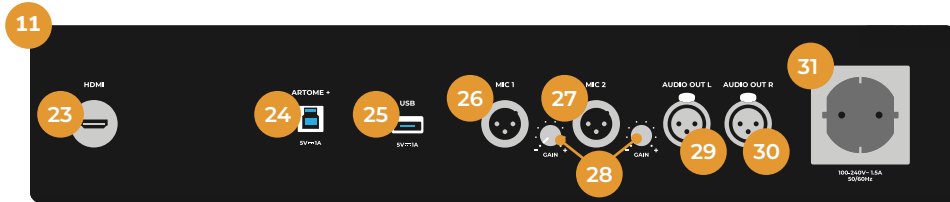

Anschlusspanel

23. HDMI 27. MIC 2
24. ARTOME+ 28. GAIN
25. USB 29. AUDIO OUT L
26. MIC 1 30. AUDIO OUT R
31. Steckdose

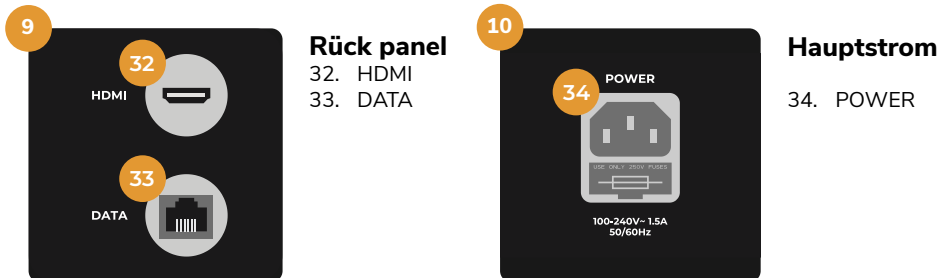

Rück panel

32. HDMI
33. DATA

Hauptstrom

34. POWER

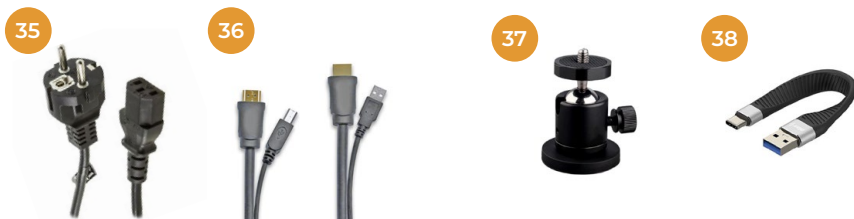

35. Netzkabel
36. HDMI-USB-Kabel

37. Kameraständer
38. USB-Kabel

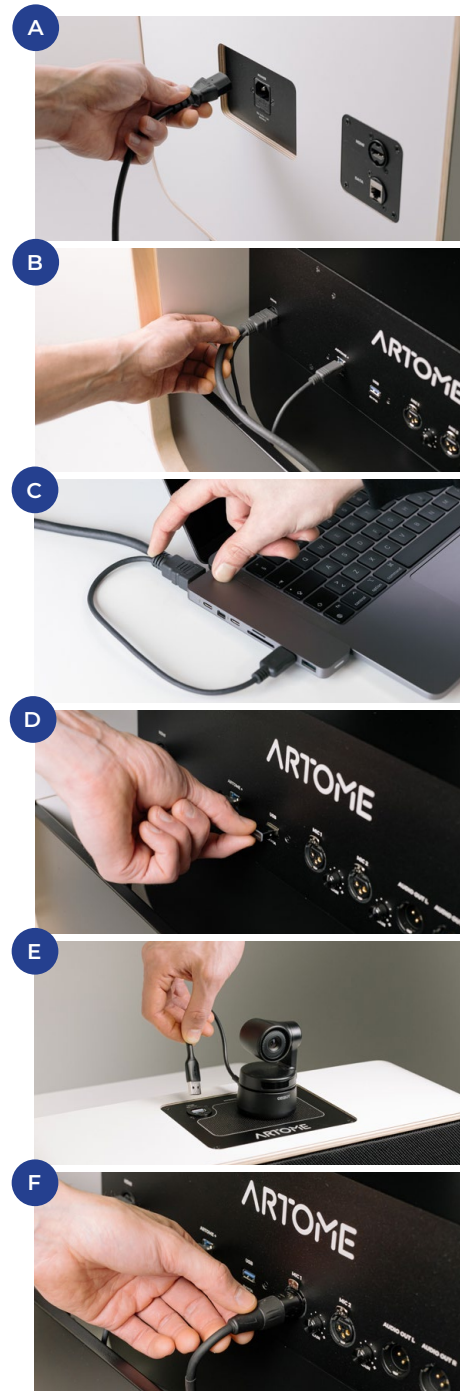

Erstmalige Verwendung

A. Schließen Sie das Netzkabel (35) an den Netzanschluss (34) an.

Öffnen Sie die Frontklappe (5) durch Drücken der Klappe in der oberen linken Ecke.

B. Führen Sie das HDMI-USB-Kabel (36) durch die Kabeldurchführung (13) und schließen Sie das Kabel an die Anschlüsse Artome HDMI (23) und ARTOME+ (24) an.

C. Verbinden Sie das HDMI-USB-Kabel (36) mit den HDMI- und USB-A-Anschlüssen Ihres Computers. Verwenden Sie bei Bedarf einen Adapter.

Artome startet automatisch, wenn Artome den HDMI-Anschluss des Computers erkennt. Schalten Sie den Artome bei Bedarf über die Taste Power (22) ein.

Verwendung von Artome bei Videokonferenzen

Über USB werden Artome und Computer mit externen USB-Geräten verbunden, die für Videokonferenzen benötigt werden.

D. Schließen Sie das USB-Kabel (38) an die Kamera an. Legen Sie die Kamera auf die obere panel (1) und schließen Sie das Kabel an den USB-Anschluss (16) an. Verwenden Sie bei Bedarf den magnetischen Kameraständer (37).







E. Stellen Sie die Kamera auf das obere panel (1) und schließen Sie das USB-Kabel (38) an den USB-Anschluss (24) an.

Verwendung des Artome für Reden

F. Schließen Sie ein dynamisches Mikrofon mit einem XLR-Kabel an den Anschluss MIC (26-27) an. Die Mikrofoneingangslautstärke kann mit den Reglern GAIN (28) eingestellt werden.

Wenn mehr Klang benötigt wird, schließen Sie zusätzliche Aktivlautsprecher mit einem XLR-Kabel an den Audio Out-Anschluss (29-30) an.

Informations importantes sur la sécurité

 	<p>Débranchez Artome de la prise de courant et confiez toutes les réparations à un personnel de service qualifié dans les situations suivantes :</p> <ul style="list-style-type: none"> De la fumée, des odeurs ou des bruits étranges sortent de l'unité Artome ou du projecteur à l'intérieur d'Artome. Du liquide ou des corps étrangers pénètrent dans l'unité Artome ou le projecteur à l'intérieur d'Artome. Artome a été endommagé. <p>Si vous continuez à utiliser Artome en l'état, vous risquez de vous électrocuter ou de provoquer un incendie. N'essayez pas de réparer l'unité Artome vous-même.</p> <p>Placez Artome près d'une prise de courant facilement accessible afin de pouvoir débrancher la fiche immédiatement si une erreur se produit.</p>
	<p>N'ouvrez jamais le panneau utilisateur, le panneau de connexion ou le panneau d'alimentation d'Artome. Ne tentez jamais de démonter ou de modifier l'unité Artome (y compris le projecteur installé).</p> <p>Les tensions électriques à l'intérieur de l'unité Artome peuvent provoquer un incendie, un choc électrique ou des blessures graves.</p>
	<p>Ne branchez jamais l'Artome sur la prise avant que le projecteur ne soit installé et que l'unité Artome ne soit entièrement configurée. Cela pourrait endommager le produit.</p>
	<p>L'installation et le retrait du projecteur de l'unité Artome doivent toujours être effectués par une personne autorisée par Artome. Si les travaux d'installation ne sont pas effectués correctement, le produit peut ne pas fonctionner correctement et cela peut entraîner des erreurs dans l'utilisation du produit. Contactez votre revendeur pour effectuer les travaux d'installation.</p>
	<p>Utilisez uniquement le cordon d'alimentation fourni par Artome. L'utilisation d'un cordon d'alimentation inapproprié peut provoquer un incendie ou un choc électrique.</p>
	<p>N'utilisez pas un câble d'alimentation endommagé. Vous risqueriez de provoquer un incendie ou une électrocution.</p> <p>Respectez les précautions suivantes lors de la manipulation du câble d'alimentation :</p> <ul style="list-style-type: none"> Ne pas modifier le câble d'alimentation. Ne pas placer d'objets lourds sur le câble d'alimentation. Ne pas plier, tordre ou tirer excessivement sur le câble d'alimentation. Tenir le câble d'alimentation à l'écart des appareils électriques chauds. Ne pas attacher le câble d'alimentation à d'autres câbles. <p>Si le câble d'alimentation est endommagé, contactez votre revendeur.</p>

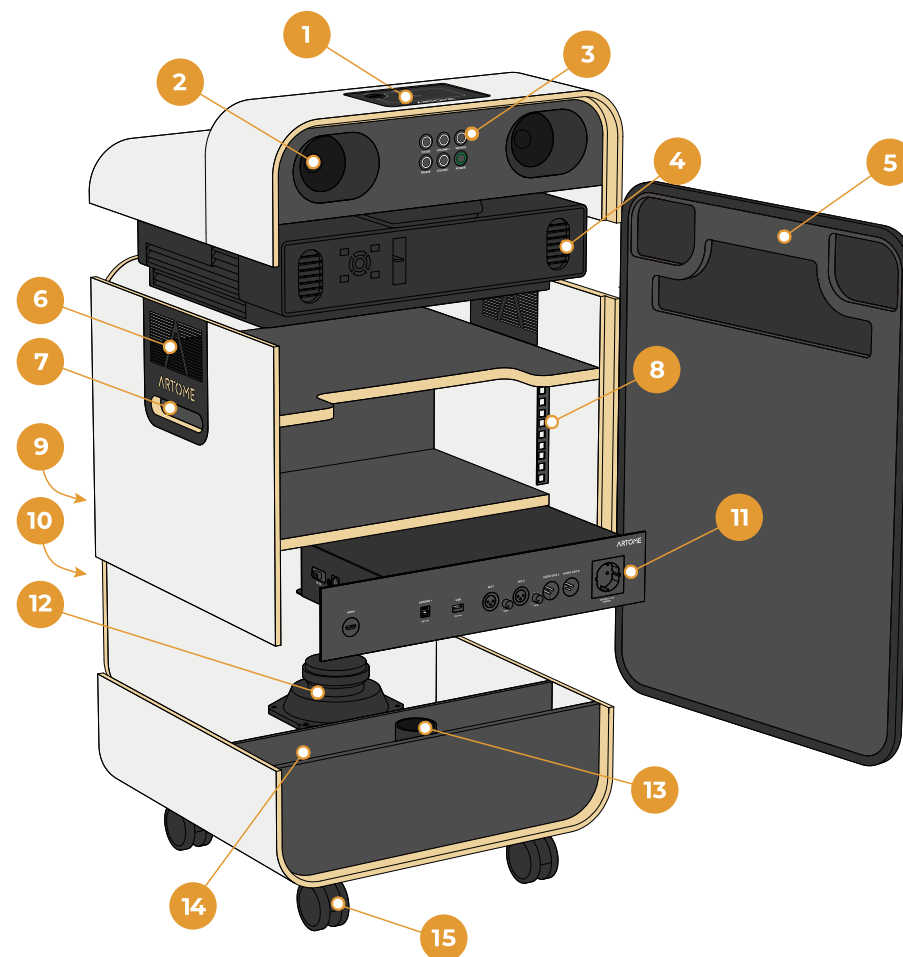

Description du produit

- | | |
|-----------------------------|-----------------------------|
| 1. Panneau supérieur | 9. Panneau arrière |
| 2. Haut-parleurs | 10. Alimentation principale |
| 3. Panneau de l'utilisateur | 11. Panneau de connexion |
| 4. Projecteur | 12. Subwoofer |
| 5. Porte | 13. Passe-câbles |
| 6. Ventilateur | 14. Espace pour câbles |
| 7. Poignée de levage | 15. Roulettes |
| 8. 19" rack | |

Artome support
support@artome.fi



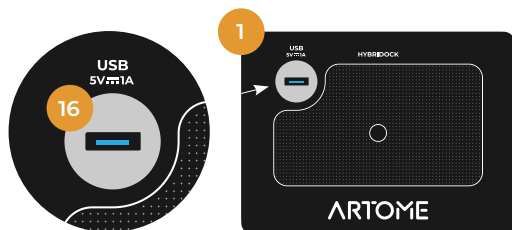

Panneau supérieur

16. USB pour caméra externe

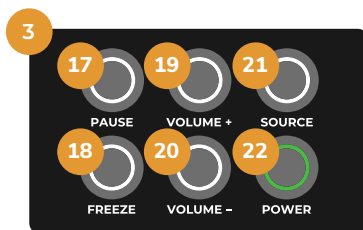

Panneau utilisateur

17. PAUSE 20. VOLUME -
18. FREEZE 21. SOURCE
19. VOLUME + 22. POWER

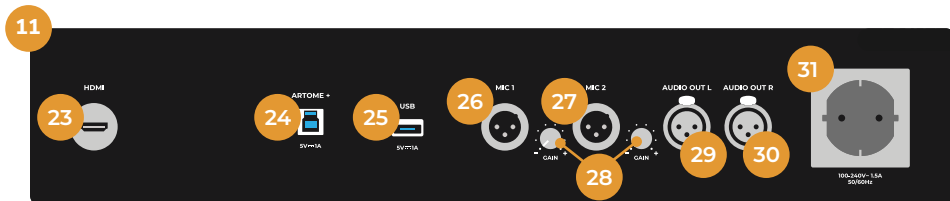

Connection panel

23. HDMI 27. MIC 2
24. ARTOME+ 28. GAIN
25. USB 29. AUDIO OUT L
26. MIC 1 30. AUDIO OUT R
31. Prise de courant

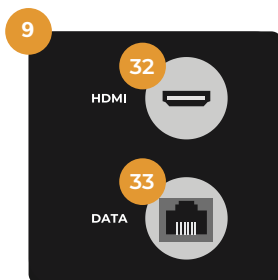

Panneau arrière

32. HDMI
33. DATA

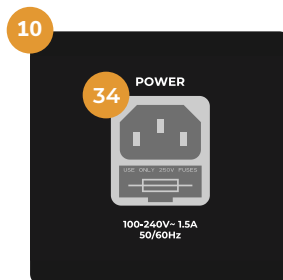

Alimentation principale

34. POWER



35. Câble d'alimentation
36. Câble HDMI-USB



37. Support de caméra
38. Câble USB

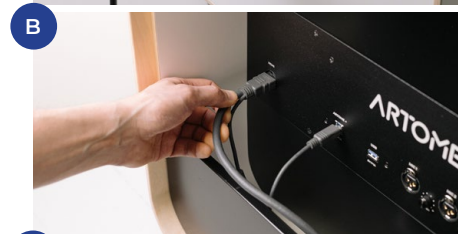

Première utilisation

A. Connectez le câble d'alimentation (35) au connecteur d'alimentation (34).

Ouvrez la porte avant (5) en appuyant sur la porte dans le coin supérieur gauche.

B. Faites passer le câble HDMI-USB (36) par le passe-câble (13) et connectez le câble aux connecteurs Artome HDMI (23) et ARTOME+ (24).

C. Connectez le câble HDMI-USB (36) aux ports HDMI et USB A de votre ordinateur. Utilisez un adaptateur si nécessaire.

Artome démarre automatiquement lorsque Artome détecte le HDMI de l'ordinateur. Si nécessaire, allumez Artome à partir du bouton d'alimentation (22).

Utilisation d'Artome en vidéoconférence

L'USB connecte Artome et l'ordinateur à des périphériques USB externes, qui sont nécessaires pour la vidéoconférence.

D. Lorsque vous utilisez le haut-parleur pour l'audio, installez le dongle USB sans fil du haut-parleur externe sur le port USB (25).







E. Connectez le câble USB (38) à l'appareil photo. Placez l'appareil photo sur le panneau supérieur (1) et connectez le câble au port USB (16). Si nécessaire, utilisez le support magnétique de l'appareil photo (37).

Utilisation d'Artome pour les discours

F. Connectez un microphone dynamique à la connexion MIC (26-27) à l'aide d'un câble XLR. Le volume de l'entrée micro peut être réglé à l'aide des commandes GAIN (28).

Si vous avez besoin de plus de son, connectez des enceintes actives supplémentaires à la connexion Audio Out (29-30) à l'aide d'un câble XLR.

Información de seguridad importante

 	<p>Desenchufe Artome de la toma de corriente y dirija todas las reparaciones a personal de servicio cualificado en las siguientes situaciones:</p> <ul style="list-style-type: none"> • Salga humo, olores extraños o ruidos extraños de la unidad Artome o del proyector dentro de Artome. • Penetran líquidos u objetos extraños en la unidad Artome o en el proyector dentro de Artome. • Artome se ha dañado. <p>Si sigue utilizando Artome tal y como está, podría provocar una descarga eléctrica o un incendio. No intente reparar la unidad Artome usted mismo.</p> <p>Coloque Artome cerca de una toma de corriente de fácil acceso para poder desenchufarlo inmediatamente si se produce un error.</p>
	<p>Nunca abras el panel de usuario, el panel de conexión o el panel de alimentación de Artome. Nunca intente desmontar o modificar la unidad Artome (incluido el proyector instalado).</p> <p>Las tensiones eléctricas en el interior de la unidad Artome pueden provocar un incendio, una descarga eléctrica o lesiones graves.</p>
	<p>Nunca conecte Artome a la toma de corriente antes de que el proyector esté instalado y la unidad Artome esté completamente configurada. Esto podría dañar el producto.</p>
	<p>La instalación y el desmontaje del proyector de la unidad Artome debe realizarla siempre una persona autorizada por Artome. Si el trabajo de instalación no se realiza correctamente, el producto puede no funcionar correctamente y puede causar errores en el uso del producto. Póngase en contacto con su distribuidor para realizar el trabajo de instalación.</p>
	<p>Utilice únicamente el cable de alimentación suministrado por Artome. El uso de un cable de alimentación inadecuado puede provocar un incendio o una descarga eléctrica.</p>
	<p>No utilice un cable de alimentación dañado. Podría producirse un incendio o una descarga eléctrica.</p> <p>Siga estas precauciones al manipular el cable de alimentación:</p> <ul style="list-style-type: none"> • No modifique el cable de alimentación. • No coloque objetos pesados sobre el cable de alimentación. • No doble, retuerza ni tire excesivamente del cable de alimentación. • Mantenga el cable de alimentación alejado de aparatos eléctricos calientes. • No ate el cable de alimentación a otros cables. <p>Si el cable de alimentación está dañado, póngase en contacto con su distribuidor.</p>

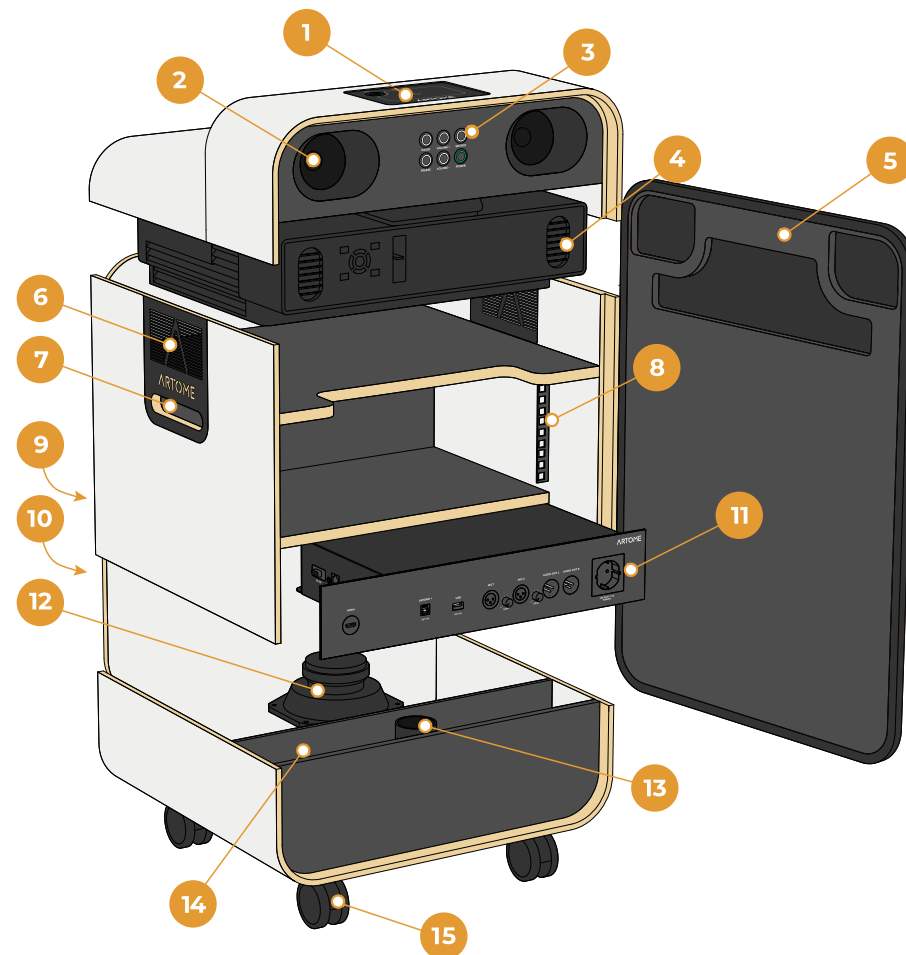

Descripción del producto

- | | |
|---------------------|----------------------------|
| 1. Panel superior | 9. Panel trasero |
| 2. Altavoces | 10. Alimentación principal |
| 3. Panel de usuario | 11. Panel de conexión |
| 4. Proyector | 12. Subwoofer |
| 5. Puerta | 13. Pasacables |
| 6. Ventilador | 14. Espacio para cables |
| 7. Asa de elevación | 15. Ruedas |
| 8. 19" rack | |

Artome support
support@artome.fi



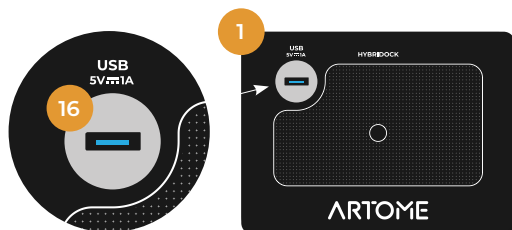

Panel superior

16. USB para cámara externa

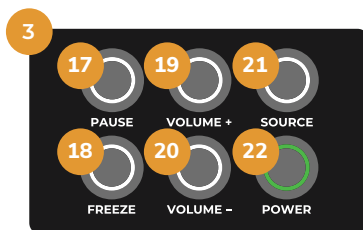

Panel de usuario

17. PAUSE 20. VOLUME -
18. FREEZE 21. SOURCE
19. VOLUME + 22. POWER

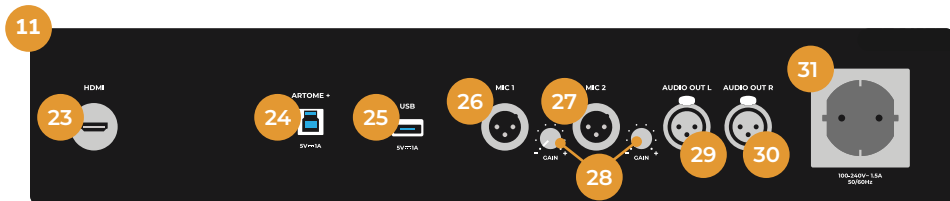

Panel de conexión

23. HDMI 27. MIC 2
24. ARTOME+ 28. GAIN
25. USB 29. AUDIO OUT L
26. MIC 1 30. AUDIO OUT R
31. Toma de corriente

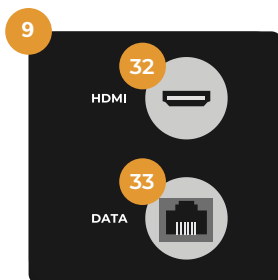

Panel trasero

32. HDMI
33. DATA

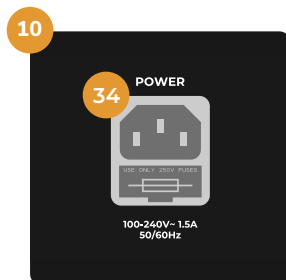

Alimentación principal

34. POWER



35. Cable de alimentación
36. Cable HDMI-USB



37. Soporte de la cámara
38. Cable USB



Primer uso

A. Conecte el cable de alimentación (35) al conector de alimentación (34).

Abra la puerta frontal (5) presionando la puerta situada en la esquina superior izquierda.

B. Pase el cable HDMI-USB (36) a través del pasacables (13) y conecte el cable a los conectores Artome HDMI (23) y ARTOME+ (24).

C. Conecte el cable HDMI-USB (36) a los puertos HDMI y USB A de su ordenador. Utilice un adaptador si es necesario.

Artome se inicia automáticamente cuando detecta el HDMI del ordenador. Si es necesario, encienda Artome desde el botón de encendido (22).

Uso de Artome en videoconferencia

USB conecta Artome y el ordenador a dispositivos USB externos, necesarios para videoconferencias.

D. Cuando utilices el altavoz para el audio; instala el Dongle USB inalámbrico del altavoz externo en el puerto USB (25).

E. Conecte el cable USB (38) a la cámara. Coloque la cámara sobre el panel superior (1) y conecte el cable al puerto USB (16). Si es necesario, utilice el soporte magnético de la cámara (37).

Uso de Artome para discursos

F. Conecte un micrófono dinámico a la conexión MIC (26-27) con un cable XLR. El volumen de la entrada de micrófono puede ajustarse con los controles de ganancia de micrófono (28).

Si necesita más sonido, conecte altavoces activos adicionales a la conexión Audio Out (29-30) con cable XLR.

Importanti informazioni sulla sicurezza

 	<p>Scollegare Artome dalla presa di corrente e rivolgersi a personale di assistenza qualificato nelle seguenti situazioni:</p> <ul style="list-style-type: none"> • Dall'unità Artome o dal proiettore all'interno di Artome fuoriescono fumo, strani odori o strani rumori. • Liquido o oggetti estranei penetrano nell'unità Artome o nel proiettore all'interno di Artome. • Artome è stato danneggiato. <p>Se si continua a utilizzare Artome così com'è, si potrebbero verificare scosse elettriche o incendi. Non cercare di riparare l'unità Artome da soli.</p> <p>Collocare Artome vicino a una presa di corrente facilmente accessibile, in modo da poter staccare immediatamente la spina in caso di errore.</p>
	<p>Non aprire mai il pannello utente, il pannello di connessione o il pannello di alimentazione di Artome. Non tentare mai di smontare o modificare l'unità Artome (compreso il proiettore installato).</p> <p>Le tensioni elettriche all'interno dell'unità Artome possono causare incendi, scosse elettriche o gravi lesioni.</p>
	<p>Non collegare mai Artome alla presa di corrente prima che il proiettore sia installato e l'unità Artome sia completamente collegata. Ciò potrebbe danneggiare il prodotto.</p>
	<p>L'installazione e la rimozione del proiettore dall'unità Artome devono sempre essere eseguite da personale autorizzato Artome. Se l'installazione non viene eseguita correttamente, il prodotto potrebbe non funzionare correttamente e causare errori nell'uso del prodotto. Rivolgersi al rivenditore per eseguire l'installazione.</p>
	<p>Utilizzare esclusivamente il cavo di alimentazione fornito da Artome. L'uso di un cavo di alimentazione inadeguato può causare incendi o scosse elettriche.</p>
	<p>Non utilizzare un cavo di alimentazione danneggiato. Potrebbero verificarsi incendi o scosse elettriche.</p> <p>Seguire le seguenti precauzioni quando si maneggia il cavo di alimentazione:</p> <ul style="list-style-type: none"> • Non modificare il cavo di alimentazione. • Non collocare oggetti pesanti sul cavo di alimentazione. • Non piegare, torcere o tirare eccessivamente il cavo di alimentazione. • Tenere il cavo di alimentazione lontano da apparecchi elettrici caldi. • Non legare il cavo di alimentazione ad altri cavi. <p>Se il cavo di alimentazione è danneggiato, contattare il rivenditore.</p>

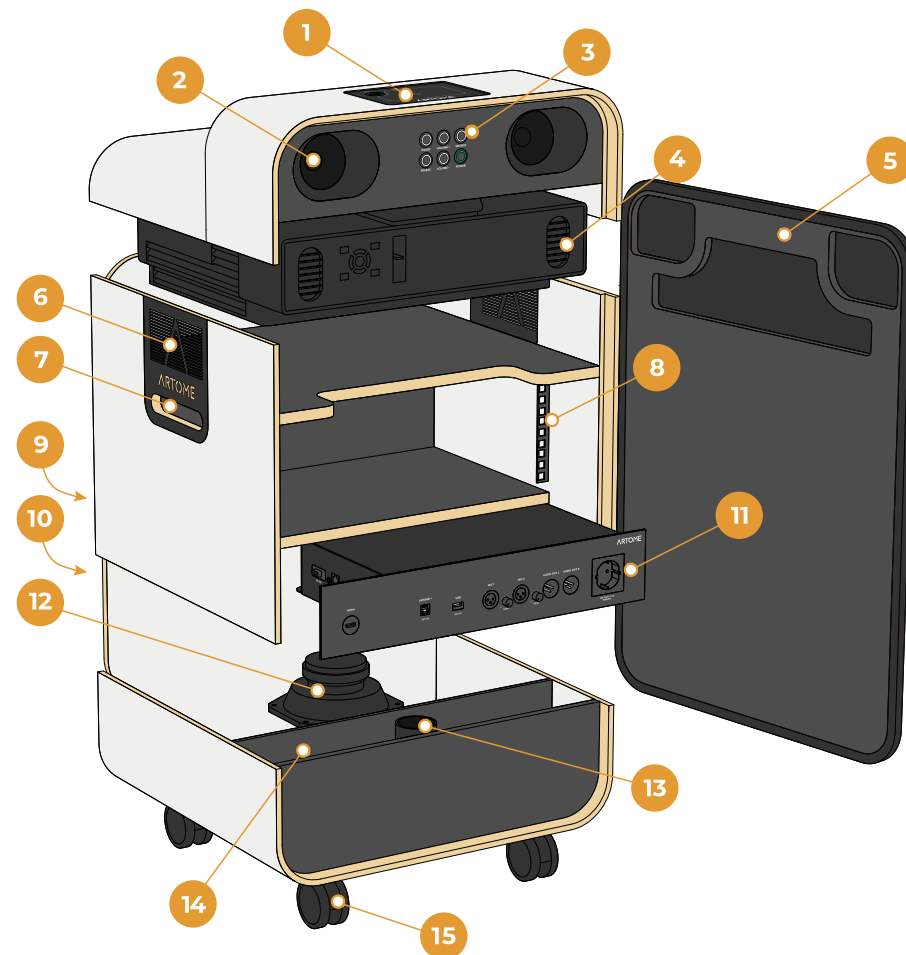

Descrizione del prodotto

- | | |
|-----------------------------|------------------------------|
| 1. Pannello superiore | 9. Pannello posteriore |
| 2. Altoparlanti | 10. Alimentazione principale |
| 3. Pannello utente | 11. Pannello di connessione |
| 4. Proiettore | 12. Subwoofer |
| 5. Porta | 13. Passacavo |
| 6. Ventilatore | 14. Spazio per i cavi |
| 7. Maniglia di sollevamento | 15. Rotelle |
| 8. 19" rack | |

Artome support
support@artome.fi



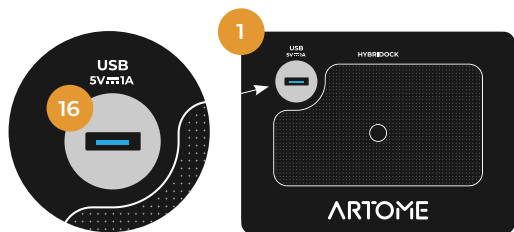

Pannello superiore

16. USB per camera esterna

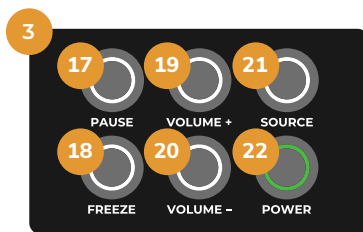

Pannello utente

17. PAUSE 20. VOLUME -
18. FREEZE 21. SOURCE
19. VOLUME + 22. POWER

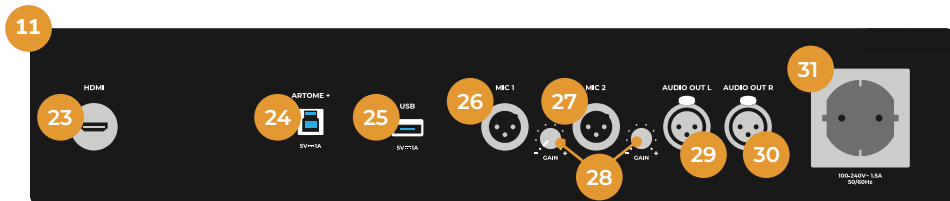

Pannello di connessione

23. HDMI 27. MIC 2
24. ARTOME+ 28. GAIN
25. USB 29. AUDIO OUT L
26. MIC 1 30. AUDIO OUT R
31. Presa di corrente

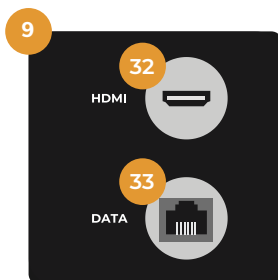

Pannello posteriore

32. HDMI
33. DATA

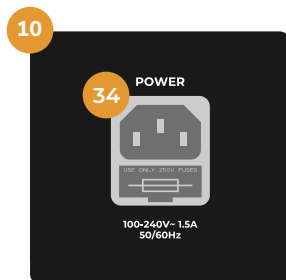

Alimentazione principale

34. POWER



35. Cavo di alimentazione
36. Cavo HDMI-USB



37. Supporto della telecamera
38. Cavo USB

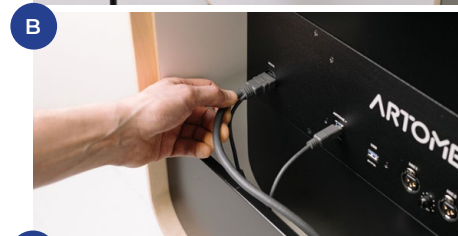

Primo utilizzo

A. Collegare il cavo di alimentazione (35) al connettore di alimentazione (34).

Aprire lo sportello anteriore (5) premendo lo sportello nell'angolo superiore sinistro.

B. Far passare il cavo HDMI-USB (36) attraverso il passacavo (13) e collegarlo ai connettori Artome HDMI (23) e ARTOME+ (24).

C. Collegare il cavo HDMI-USB (36) alle porte HDMI e USB A del computer. Se necessario, utilizzare un adattatore.

Artome si avvia automaticamente quando rileva l'HDMI dal computer. Se necessario, accendere Artome dal pulsante di alimentazione (22).

Utilizzo di Artome in videoconferenza

USB collega Artome e il computer a dispositivi USB esterni, necessari per le videoconferenze.

D. Quando si utilizza il vivavoce per l'audio, installare il dongle USB wireless del vivavoce esterno nella porta USB (25).







E. Collegare il cavo USB (38) alla fotocamera. Posizionare la fotocamera sul pannello superiore (1) e collegare il cavo alla porta USB (16). Se necessario, utilizzare il supporto magnetico della fotocamera (37).

Utilizzo di Artome per i discorsi

F. Collegare un microfono dinamico alla connessione MIC (26-27) con un cavo XLR. Il volume dell'ingresso microfonico può essere regolato con i controlli GAIN (28).

Se è necessario un suono più intenso, collegare altri altoparlanti attivi alla connessione Audio Out (29-30) con un cavo XLR.

Belangrijke veiligheidsinformatie

 	<p>Haal de stekker van Artome uit het stopcontact en laat alle reparaties uitvoeren door gekwalificeerd onderhoudspersoneel in de volgende situaties:</p> <ul style="list-style-type: none"> • Rook, vreemde geuren of vreemde geluiden komen uit het Artome apparaat of de projector in Artome. • Er komen vloeistoffen of vreemde voorwerpen in het Artome apparaat of de projector in Artome. • Artome is beschadigd. <p>Als u Artome blijft gebruiken zoals het is, kan het een elektrische schok of brand veroorzaken.</p> <p>Plaats Artome in de buurt van een gemakkelijk toegankelijk stopcontact, zodat de stekker onmiddellijk uit het stopcontact kan worden getrokken als zich een fout voordoet.</p>
	<p>Open nooit het Artome gebruikerspaneel, aansluitpaneel of voedingspaneel. Probeer nooit de Artome-unit (inclusief geïnstalleerde projector) te demonteren of aan te passen.</p> <p>Elektrische spanningen in het Artome apparaat kunnen brand, elektrische schokken of ernstig letsel veroorzaken.</p>
	<p>Steek nooit de stekker van de Artome in het stopcontact voordat de projector is geïnstalleerd en de Artome volledig is aangesloten. Dit kan het product beschadigen.</p>
	<p>Installatie en verwijdering van de projector van het Artome apparaat moet altijd worden uitgevoerd door Artome bevoegd persoon. Als de installatiewerkzaamheden niet correct worden uitgevoerd, werkt het product mogelijk niet correct en kunnen er gebreken ontstaan bij het gebruik van het product. Neem contact op met uw dealer om de installatiewerkzaamheden uit te voeren.</p>
	<p>Gebruik alleen het door Artome geleverde stroomkabel. Het gebruik van een onjuist stroomkabel kan brand of elektrische schokken veroorzaken.</p>
	<p>Gebruik geen beschadigd stroomkabel. Brand of elektrische schokken kunnen het gevolg zijn.</p> <p>Volg deze voorzorgsmaatregelen bij het hanteren van de stroomkabel:</p> <ul style="list-style-type: none"> • Breng geen wijzigingen aan in de stroomkabel. • Plaats geen zware voorwerpen op de stroomkabel. • Buig, draai of trek niet te hard aan de stroomkabel. • Houd de stroomkabel uit de buurt van hete elektrische apparaten. • Maak de stroomkabel niet vast aan andere kabels. <p>Neem contact op met uw dealer als de stroomkabel beschadigd is.</p>

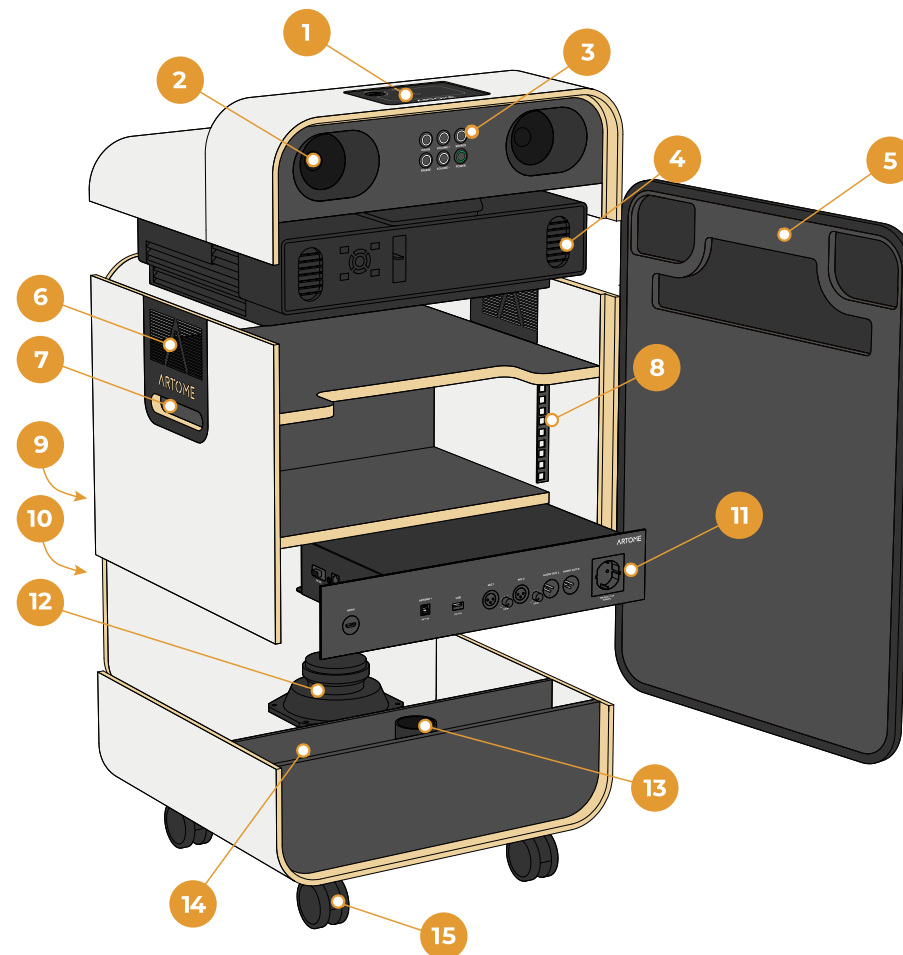

Beschrijving van het product

- | | |
|---------------------|------------------------|
| 1. Bovenpaneel | 9. Achterpaneel |
| 2. Luidsprekers | 10. Hoofdvoeding |
| 3. Gebruikerspaneel | 11. Aansluitingspaneel |
| 4. Projector | 12. Subwoofer |
| 5. Deur | 13. Kabeldoorvoer |
| 6. Ventilator | 14. Kabel ruimte |
| 7. Tilgreep | 15. Wielen |
| 8. 19" rack | |

Artome support
support@artome.fi





Bovenpaneel

16. USB voor externe camera

Gebruikerspaneel

17. PAUSE 20. VOLUME -
18. FREEZE 21. SOURCE
19. VOLUME + 22. POWER

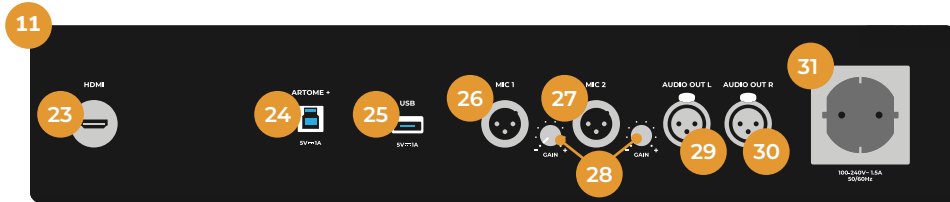

Aansluitingspaneel

23. HDMI 27. MIC 2
24. ARTOME+ 28. GAIN
25. USB 29. AUDIO OUT L
26. MIC 1 30. AUDIO OUT R
31. Stopcontact

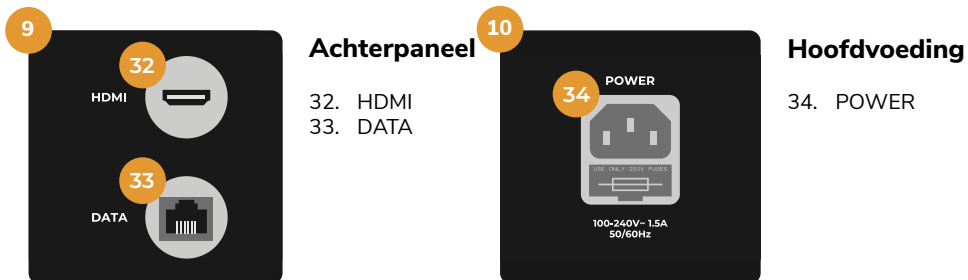

Achterpaneel

32. HDMI
33. DATA

Hoofdvoeding

34. POWER

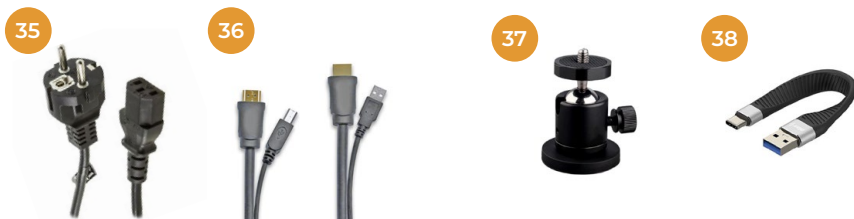

35. Stroomkabel
36. HDMI-USB-kabel

37. Camerastatief
38. USB-kabel

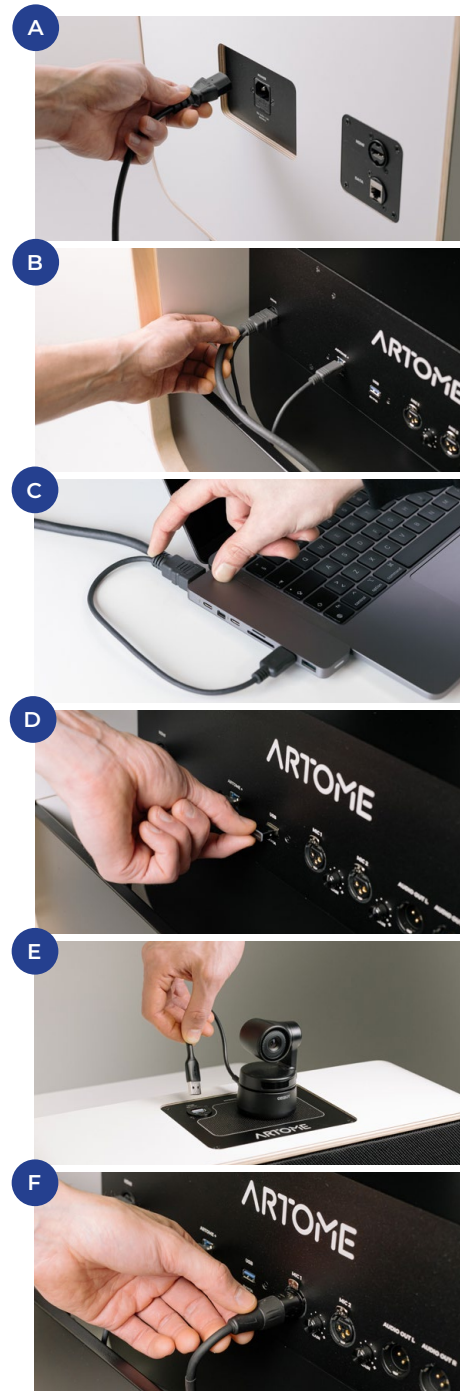

Eerste gebruik

A. Sluit de voedingskabel (35) aan op de voedingsaansluiting (34).

Open de voorklep (5) door op de deur in de linkerbovenhoek te drukken.

B. Voer de HDMI-USB-kabel (36) door de kabeldoorvoer (13) en sluit de kabel aan op de Artome HDMI (23) en ARTOME+ (24) aansluitingen.

C. Sluit de HDMI-USB-kabel (36) aan op de HDMI- en USB A-poorten van uw computer. Gebruik zo nodig een adapter.

Artome start automatisch op wanneer Artome HDMI van de computer detecteert. Schakel indien nodig de Artome in via de aan/uit-knop (22).

Artome gebruiken bij videoconferenties

USB verbindt Artome en computer met externe USB-apparaten, die nodig zijn voor videoconferenties.

D. Bij gebruik van de luidsprekertelefoon voor audio; installeer de draadloze USB-dongle van de externe luidsprekertelefoon op de USB-poort (25).

E. Sluit de USB-kabel (38) aan op de camera. Plaats de camera op het bovenpaneel (1) en sluit de kabel aan op de USB-poort (16). Gebruik indien nodig de magnetische camerasteun (37).

Artome gebruiken voor toespraken

F. Sluit een dynamische microfoon aan op de MIC (26-27) aansluiting met een XLR kabel. Het ingangsvolume van de microfoon kan worden aangepast met de GAIN regelaars (28).

Als je meer geluid nodig hebt, sluit je extra actieve luidsprekers aan op Audio Out aansluiting (29-30) met XLR kabel.